



Confidentialité et politiques
Ce document est la propriété ZAXE TECHNOLOGIES et ne peut être utilisé pour d'autres fins que celles pour lesquelles il a été préparé et soumis. Aucune reproduction ne peut être faite sans autorisation.

The information contained in this drawing is the sole property of zaxe technologies. Any reproduction in part or as a whole without the written permission is prohibited.

©2020 Tous les droits réservés /All rights reserved.

No. de produit / Product Part Number:
310-00012

Designation du produit / Product Name
TURKEY SCALE

Titre du dessin / Drawing Title
INSTALLATION GUIDE

Révision / Revision	Feuille / Sheet:
A	2/3

Matériau / Material specifications:

N/A

Unités / Units:
mm[in]

Standard Tolerances:

Inches
X/X ± 1/16"
X.XX" ±0.03"
X.XXX" ±0.010"

Millimeters
X.X ± 0.8
X.XX ±0.25

Angle
X.X° ± 0.5°

Dernière mise à jour / Last update date:

2021-08-06

Dessiné par / Drawn by:

KB

Approuvé par /Approved by:

INSTALLATION PROCEDURE

STEP 1: ASSEMBLE THE 4 PIPES WITH THE PLATFORM PLATE USING 4 HEX BOLTS AND 4 WASHER PLATES.

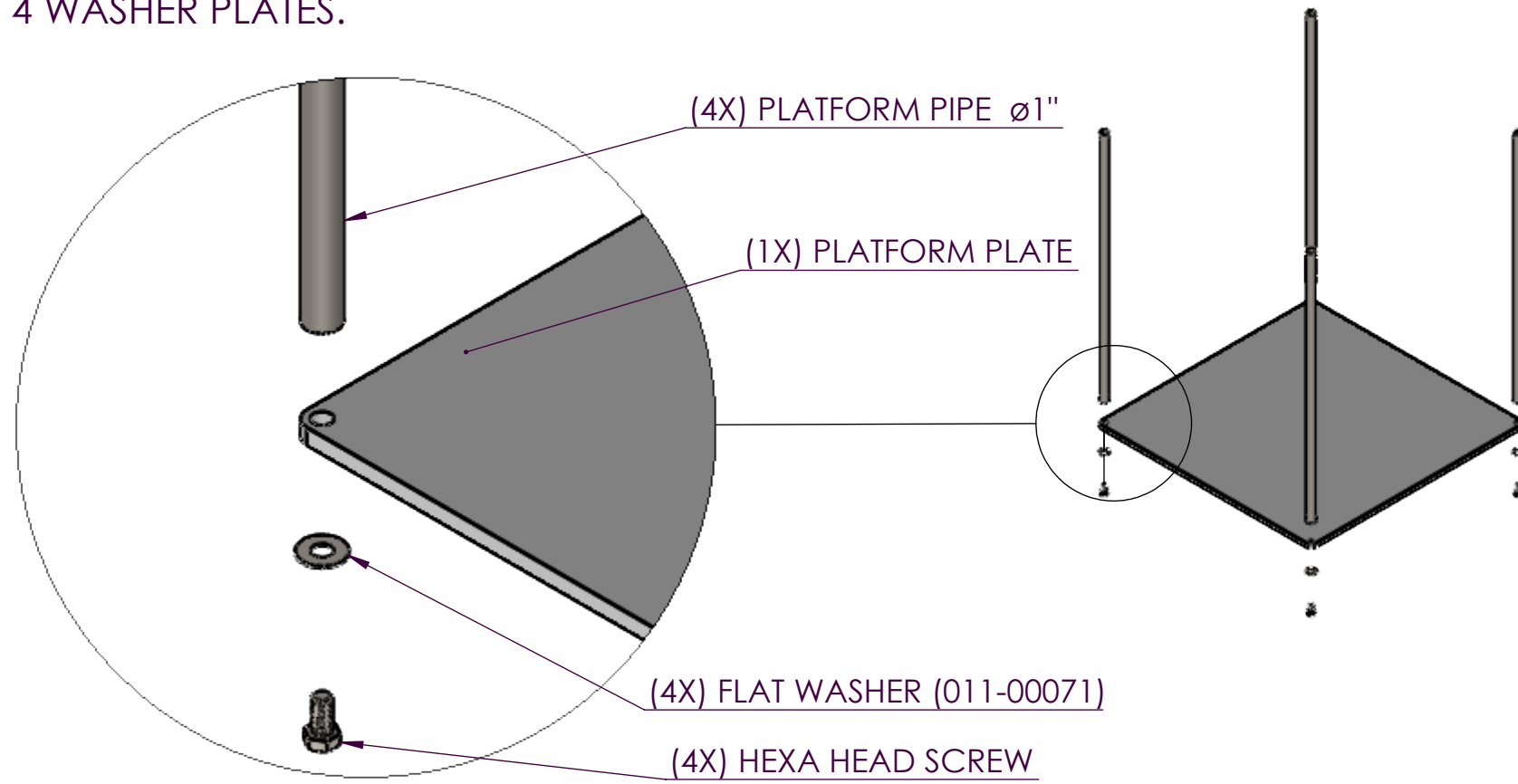

STEP3:
1: ATTACH THE ANCHOR RING TO THE CEILING USING THE 4 WOOD SCREWS.
2: HANG THE LOAD CELL ON THE ANCHOR RING USING FROM THE 1ST S-HOOK.

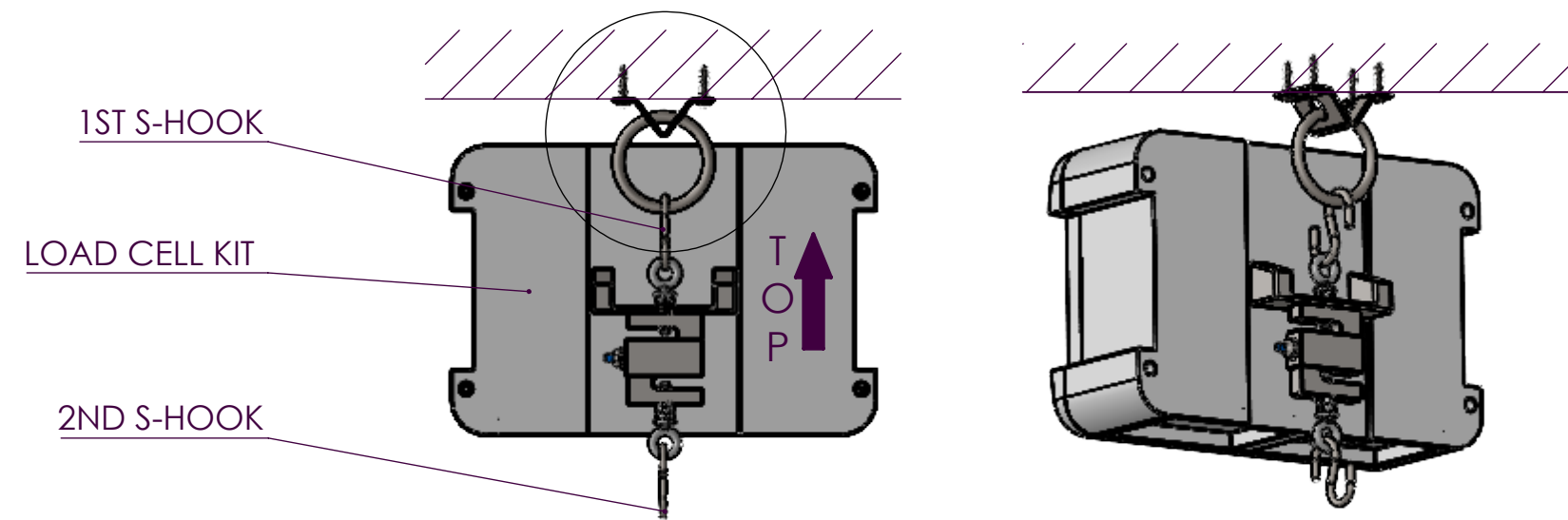
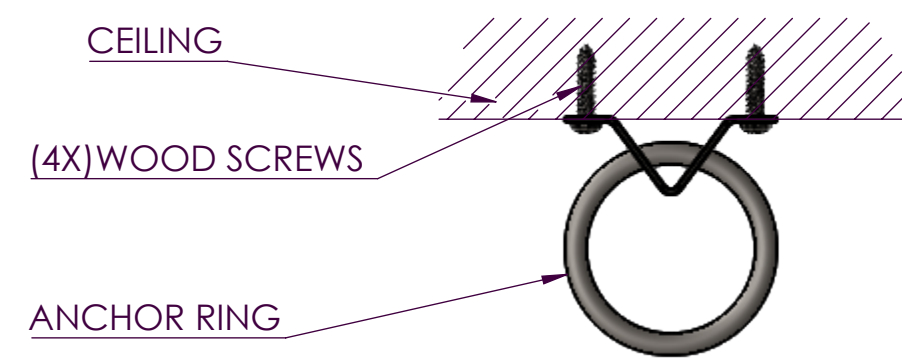

STEP 2 :
1: INSTALL RING OF THE WIRE ROPE 011-00123A ON THE TOP OF THE TUBE.
2: PLACE THE TWO CORNERS OF THE CORNER PROFILE ON THE CABLE AND SECURE THE ASSEMBLY USING A WASHER AND A HEX HEAD SCREW.
3: REPEAT THE OPERATION FOR THE 3 OTHER PIPES .

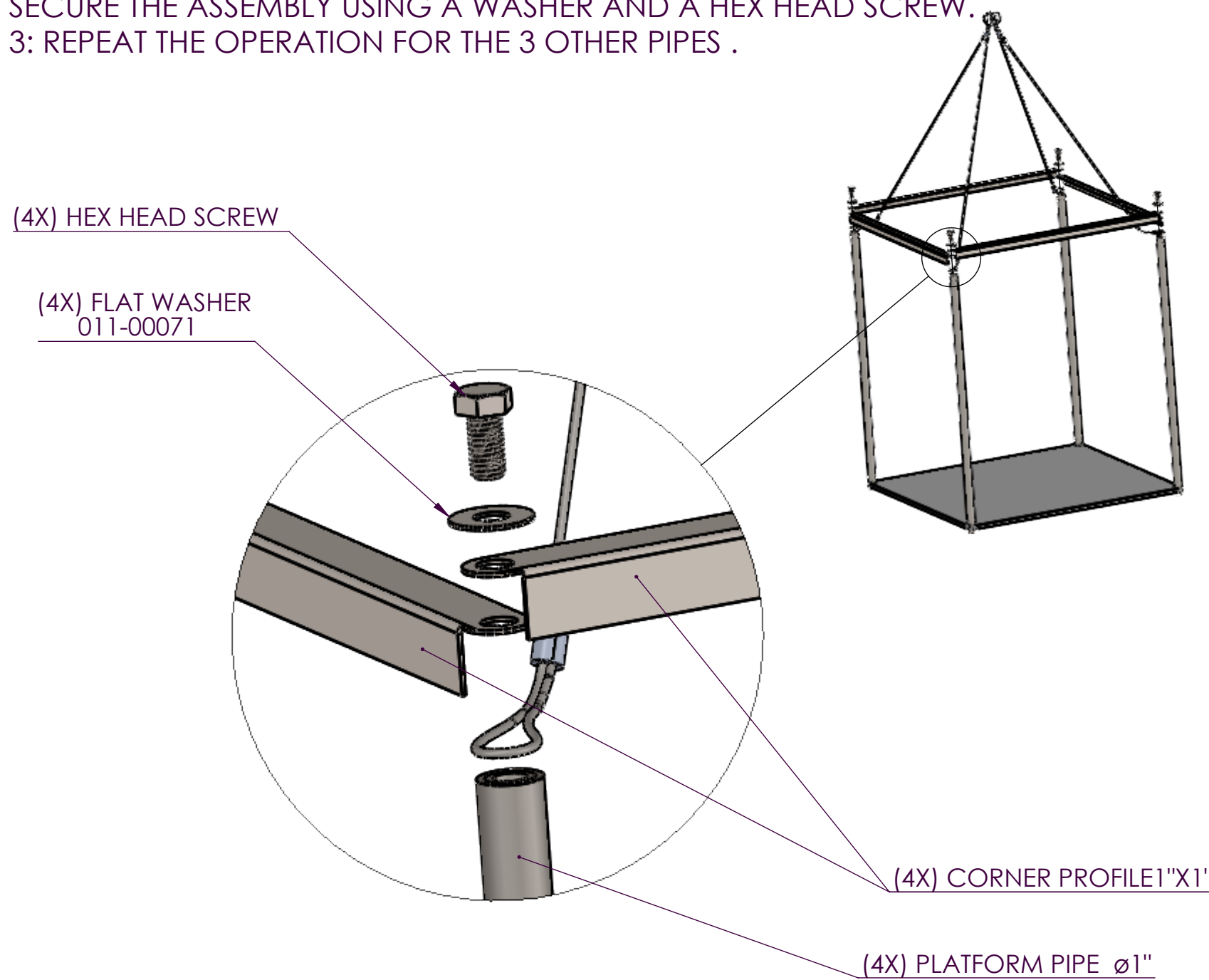

STEP4:

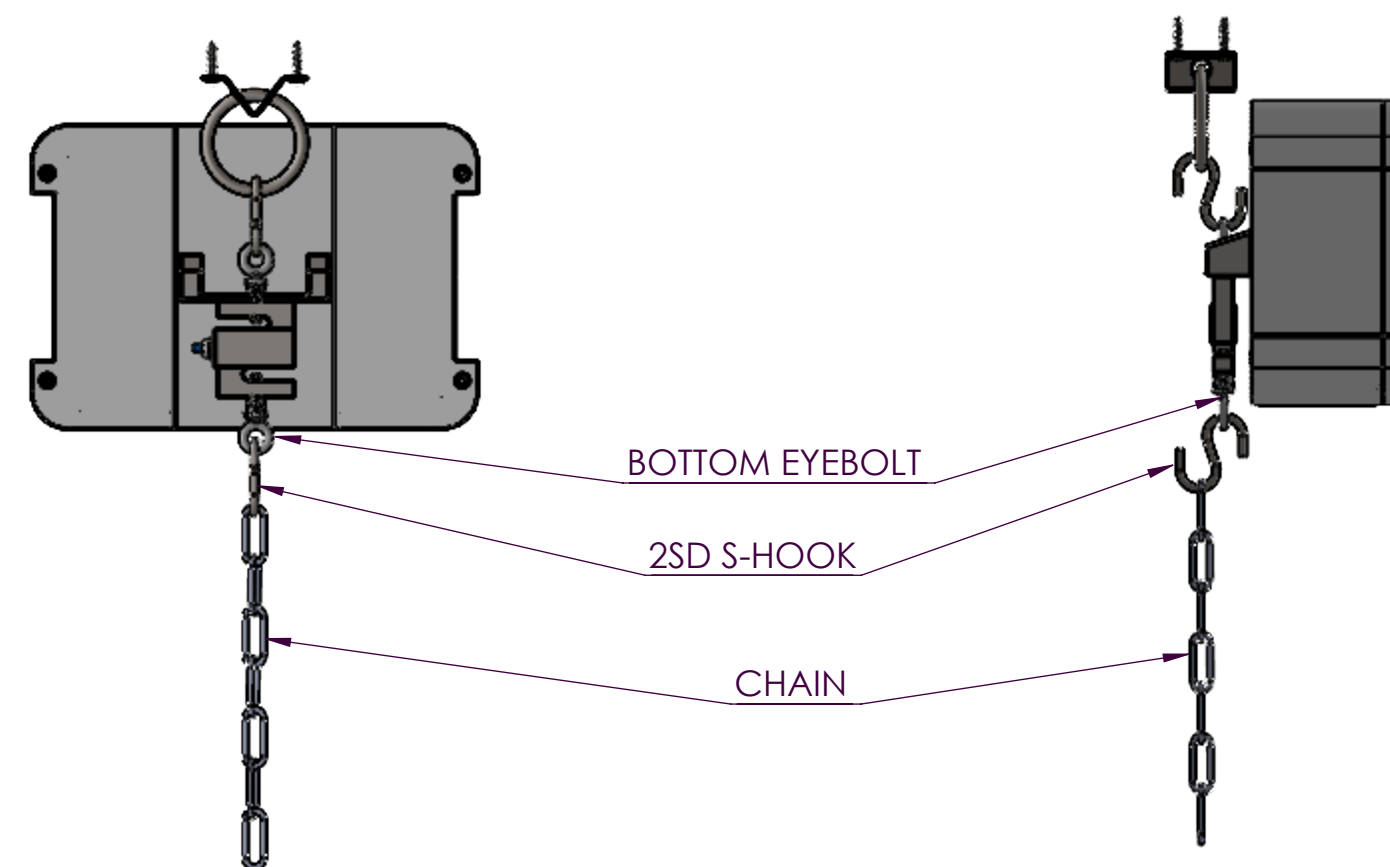

A

B

C

D

E

F

STEP 5:

- 1: ASSEMBLE THE 4 WIRE ROPE 011-00123A ON THE HEAD OF THE SHACKLE. THE SHCKLE HEAD MUST BE FACING DOWN.
- 2: ASSEMBLE THE WIRE CABLE 011-00123B ON THE SHACKLE SHAFT AND TIGHTEN IT FIRMLY ON THE SHACKLE.
- 4: ASSEMBLE THE 3RD "S" HOOK ON THE FREE END OF THE CABLE 011-00123B.

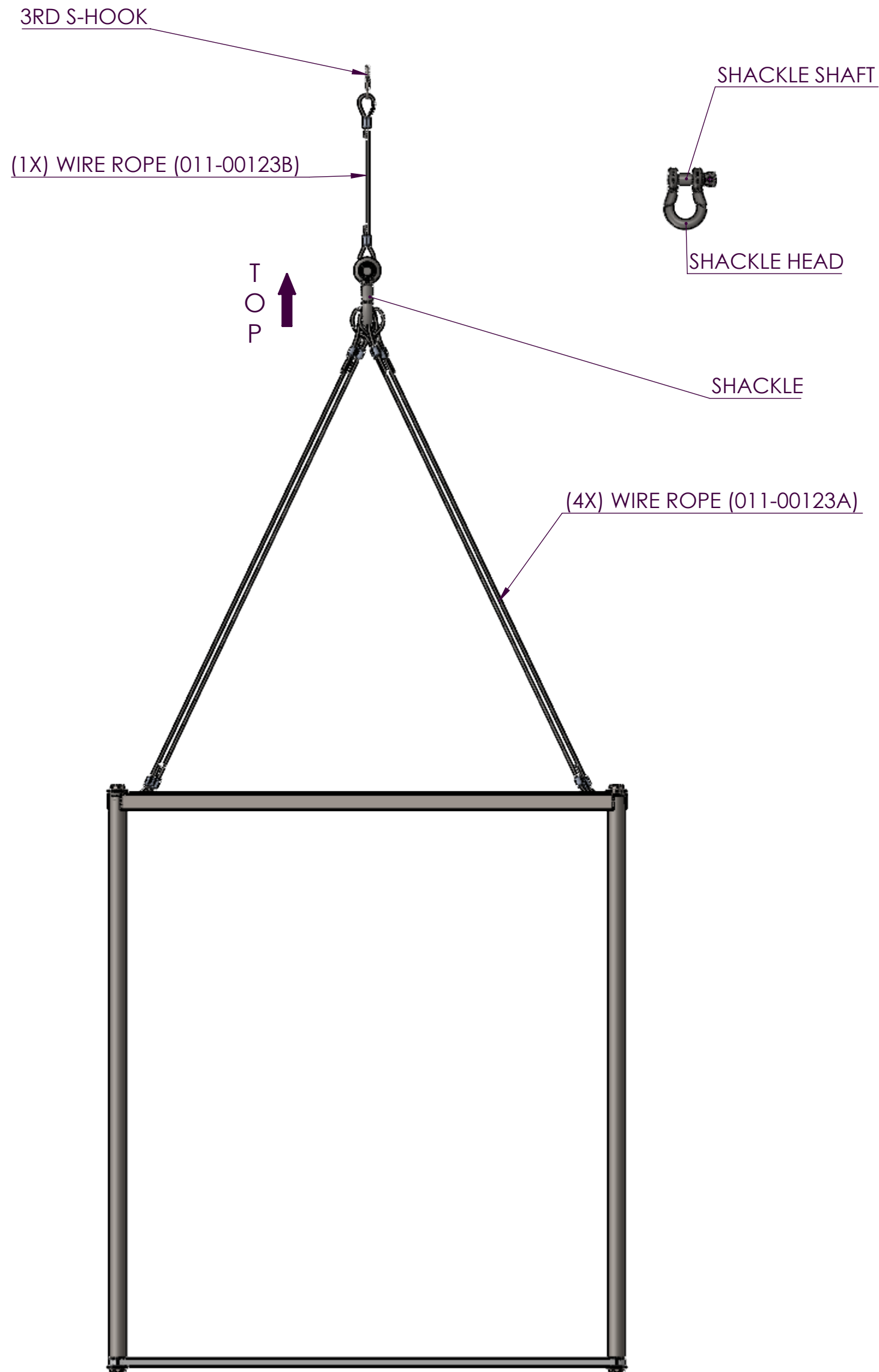

STEP 6:

- 1: USING THE 3RD S-HOOK, HANG ON THE CABLES, SHACKLE, PALTEFORM ASSEMBLY, AT THE FREE END OF THE CHAIN.
- 2: MAKE SURE TO KEEP AT MINIMUM 4"(102mm) PLATFORM PLATE / BEDDING DISTANCE.



Propriétaire



Confidentialité et politiques
 Ce document est la propriété ZAXE TECHNOLOGIES et ne peut être utilisé pour d'autres fins que celles pour lesquelles il a été préparé et soumis. Aucune reproduction ne peut être faite sans autorisation.

The information contained in this drawing is the sole property of zaxe technologies. Any reproduction in part or as a whole without the written permission is prohibited.

©2020 Tous les droits réservés /All rights reserved.

No. de produit / Product Part Number:

310-00012

Designation du produit / Product Name

TURKEY SCALE

Titre du dessin / Drawing Title

INSTALLATION GUIDE

Révision / Revision

A

Feuille / Sheet:

3/3

Matériau / Material specifications:

N/A

Unités / Units:

mm[in]

Standard Tolerances:

Inches

X/X ± 1/16"
 X.XX" ±0.03"
 X.XXX" ±0.010"

Millimeters

X.X ± 0.8
 X.XX ±0.25

Angle

X.X° ± 0.5°

Dernière mise à jour / Last update date:

2021-08-06

Dessiné par / Drawn by:

KB

Approuvé par /Approved by:

Historique de révision / Revision history:

1

2

3

4

5

6